

Finger Blanks and Intermediate Jaws

Accessories • **Gripper Jaws**

Gripper Jaws

of aluminum or steel for customized subsequent machining



Function description

Finger and jaw blanks already feature the mechanical interface to the gripper. The customer only needs to machine the blank to the specific workpiece geometry.

Your advantages and benefits

Matching finger blanks

for common gripper types

Easy mounting

thanks to standardized mounting pattern

High replacement accuracy

thanks to centering

Clamping contour

can be machined rapidly and easily

Fast delivery

Aluminum finger blanks

of high-strength aluminum alloy

Steel finger blanks

of hardenable steel

Application example



Area of application

Optional

1 KTG 2-Finger Parallel Gripper

2 RB Finger Blanks for KTG

General information

Scope of delivery
including screws

Notes

To suit your special requirements, we will be glad to supply low-cost special solutions, workpiece-specific gripper fingers, adapter plates and complete assemblies. Please ask for details.



ABR for MPG

Accessories · Gripper Jaws · **For Special Gripper Series**



Technical data

Description	ID	Items per ID	Weight [kg]	Material
ABR 20	0340210	2	0.006	Aluminum
ABR 25	0340211	2	0.008	Aluminum
ABR 32	0340212	2	0.016	Aluminum
ABR 40	0340213	2	0.031	Aluminum
ABR 50	0340214	2	0.068	Aluminum
ABR 64	0340215	2	0.12	Aluminum

ABR 20

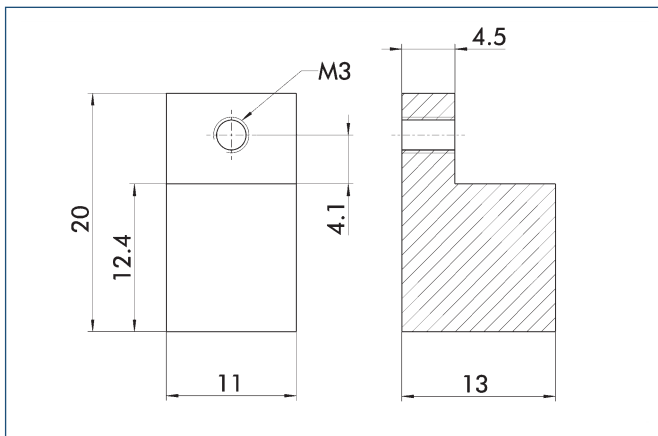

ABR 25

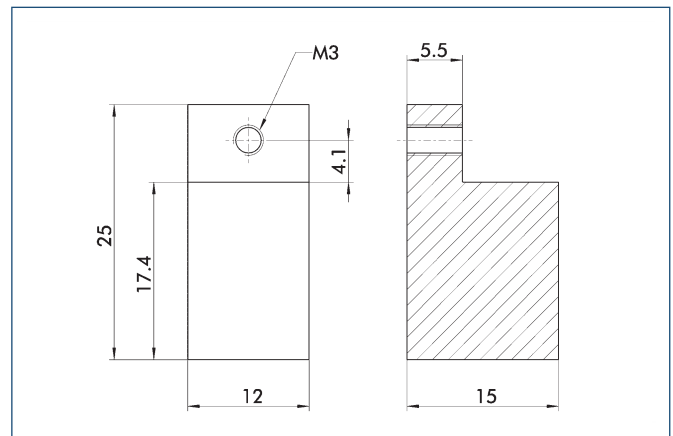

ABR 32

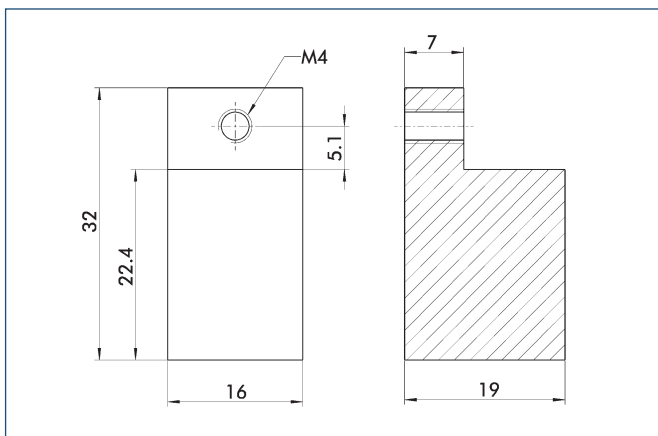

ABR 40

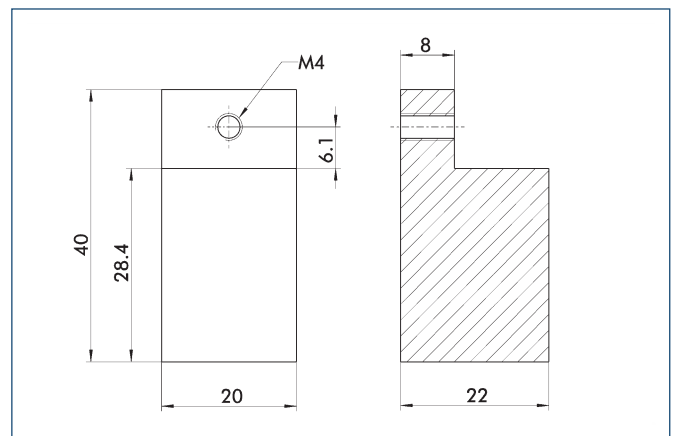

ABR for MPG

Accessories · Gripper Jaws · **For Special Gripper Series**

ABR 50

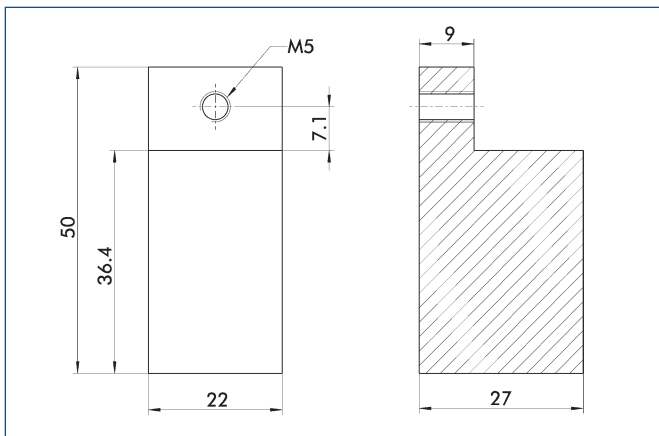

ABR 64

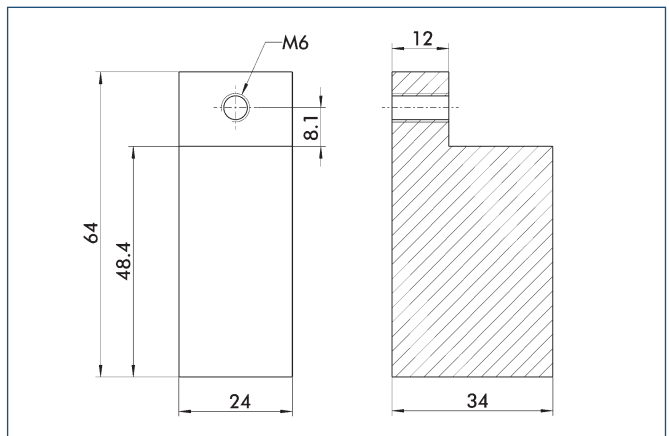

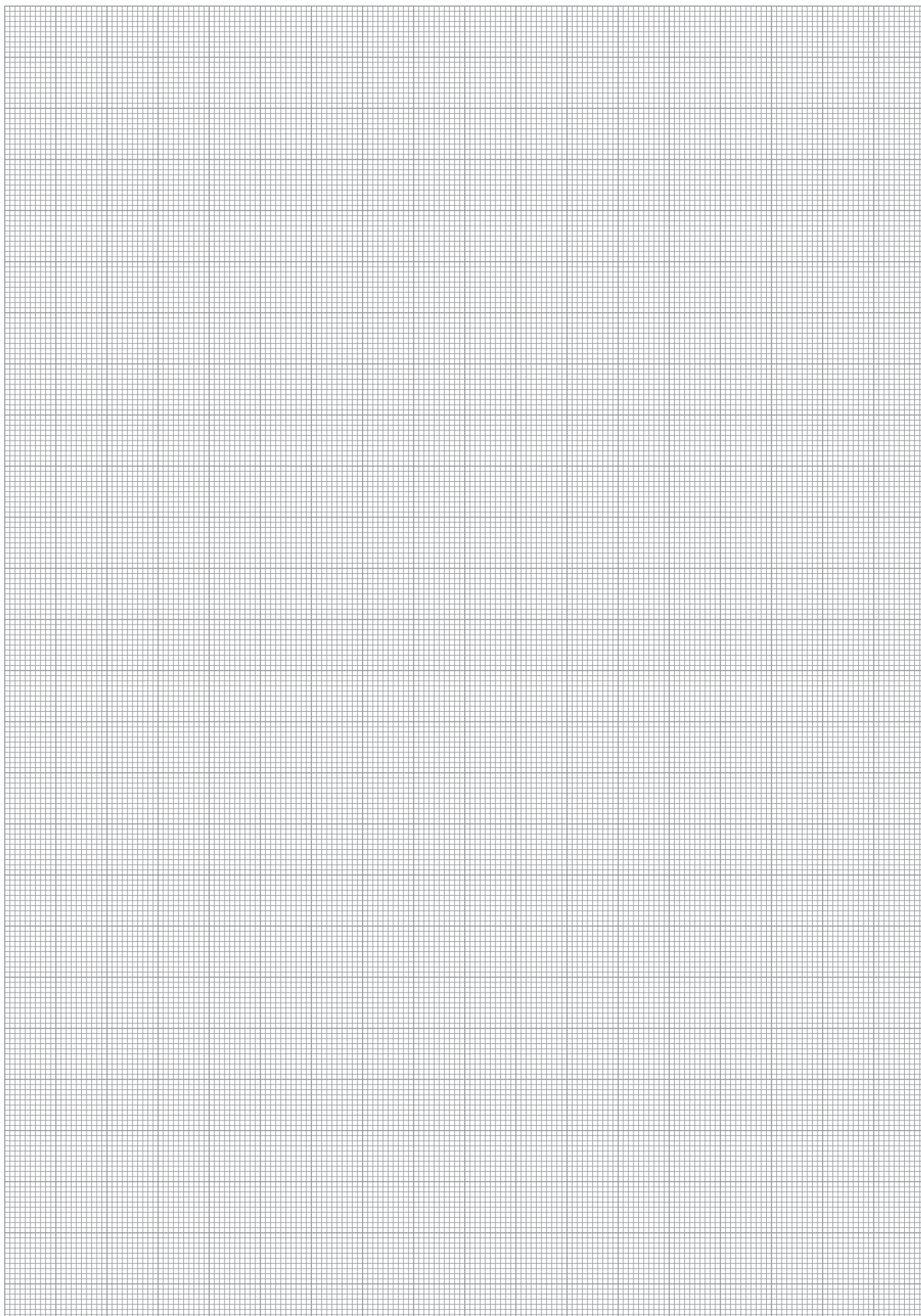

ABR for MPZ

Accessories · Gripper Jaws · For Special Gripper Series



Technical data

Description	ID	Items per ID	Weight [kg]	Material
ABR 30	0340519	3	0.08	Aluminum
ABR 38	0340529	3	0.015	Aluminum
ABR 45	0340539	3	0.024	Aluminum

ABR 30

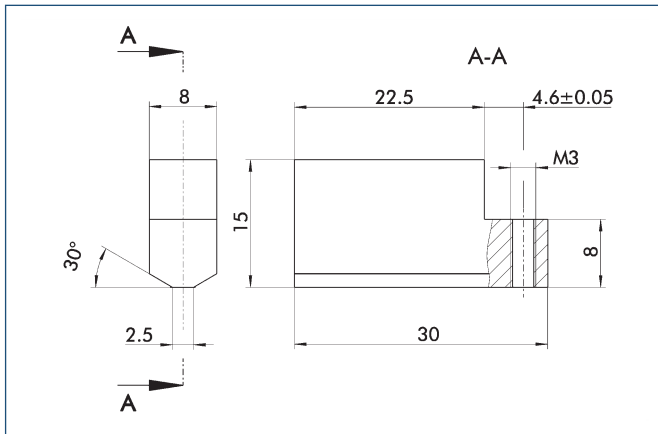

ABR 38

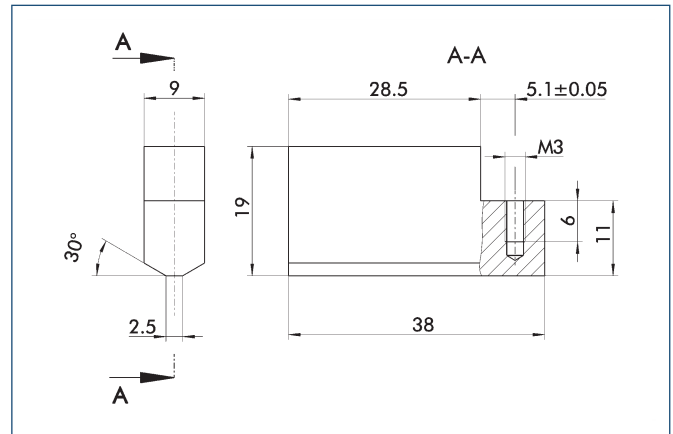

ABR 45

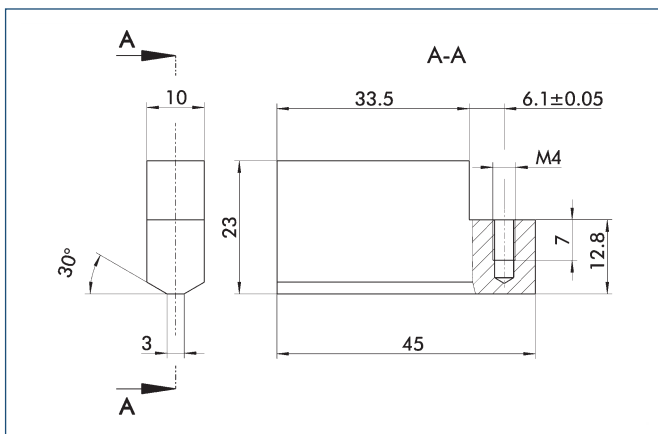



Technical data

Description	ID	Items per ID	Weight [kg]	Material
ABR-plus 40	0300008	1	0.02	Aluminum
SBR-plus 40	0300018	1	0.055	16 MnCr 5
ABR-plus 50	0300009	1	0.045	Aluminum
SBR-plus 50	0300019	1	0.125	16 MnCr 5
ABR-plus 64	0300010	1	0.093	Aluminum
SBR-plus 64	0300020	1	0.26	16 MnCr 5
ABR-plus 80	0300011	1	0.162	Aluminum
SBR-plus 80	0300021	1	0.455	16 MnCr 5
ABR-plus 100	0300012	1	0.358	Aluminum
SBR-plus 100	0300022	1	1.004	16 MnCr 5
ABR-plus 125	0300013	1	0.638	Aluminum
SBR-plus 125	0300023	1	1.788	16 MnCr 5
ABR-plus 160	0300014	1	1.291	Aluminum
SBR-plus 160	0300024	1	3.45	16 MnCr 5
ABR-plus 200	0300015	1	2.191	Aluminum
SBR-plus 200	0300025	1	6.144	16 MnCr 5
SBR-plus 240	0300027	1	7.98	16 MnCr 5
ABR-plus 240	0300017	1	2.84	Aluminum
ABR-plus 300	0300016	1	3.236	Aluminum
SBR-plus 300	0300026	1	9.072	16 MnCr 5

ABR-plus/SBR-plus 40

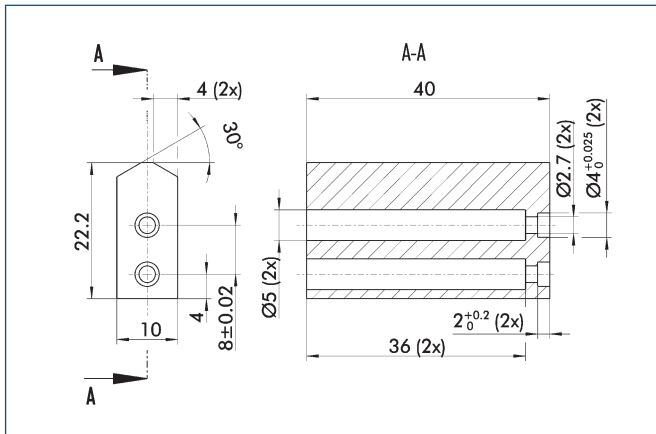

ABR-plus/SBR-plus 50

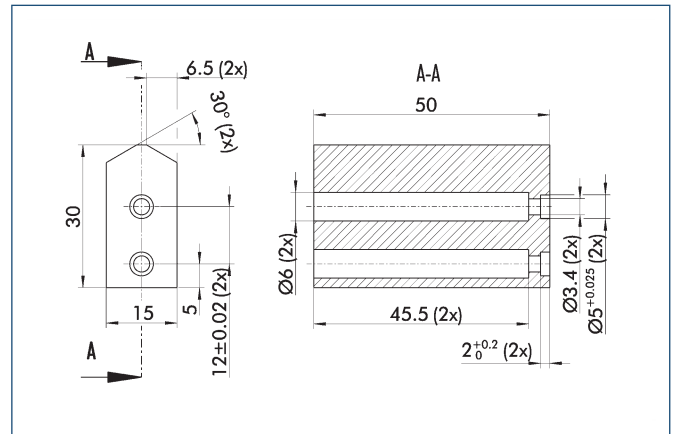

ABR-plus/SBR-plus 64

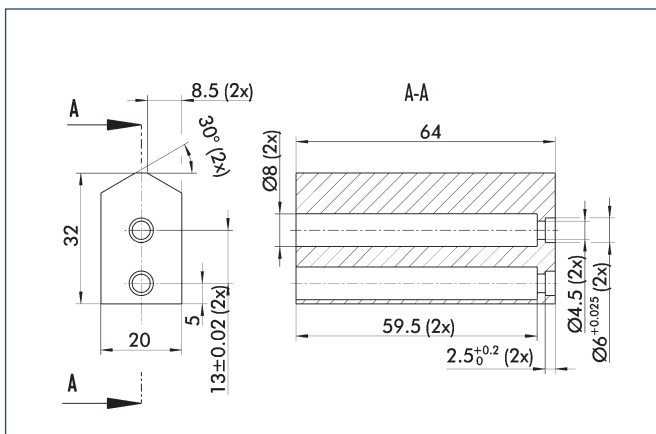

ABR-plus/SBR-plus 80

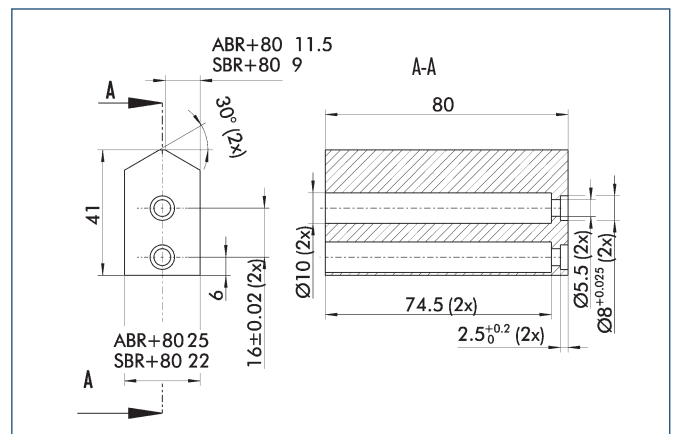

ABR-plus/SBR-plus

Accessories · Gripper Jaws · For Standard Screw Connection Diagram

ABR-plus/SBR-plus 100

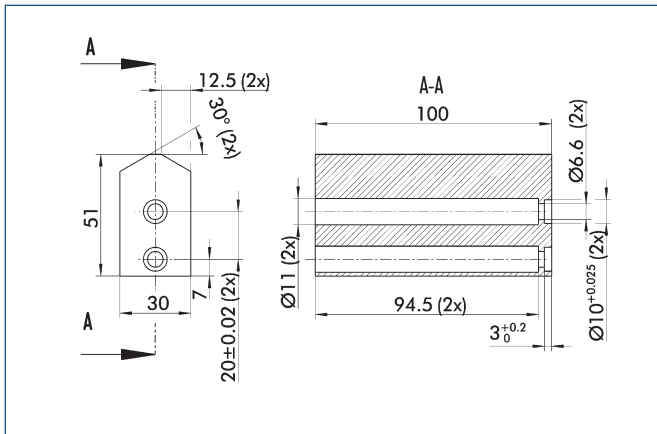

ABR-plus/SBR-plus 125

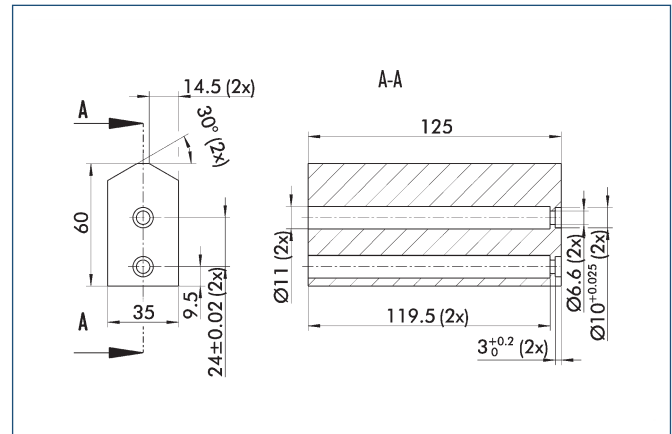

ABR-plus/SBR-plus 160

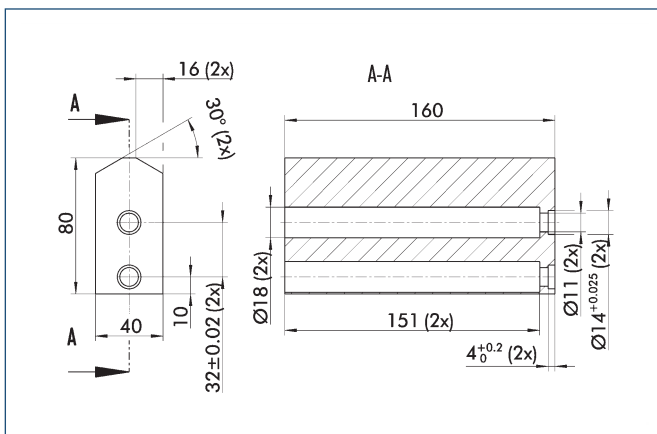

ABR-plus/SBR-plus 200

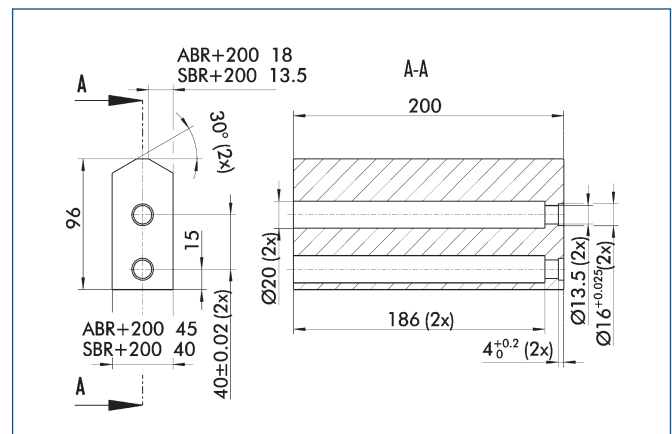

ABR-plus/SBR-plus 240

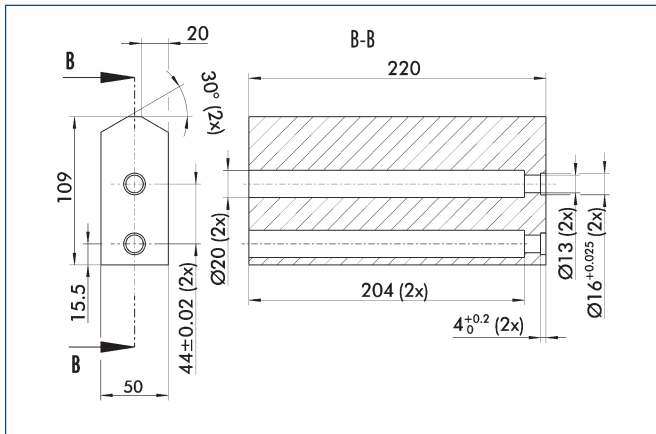

ABR-plus/SBR-plus 300

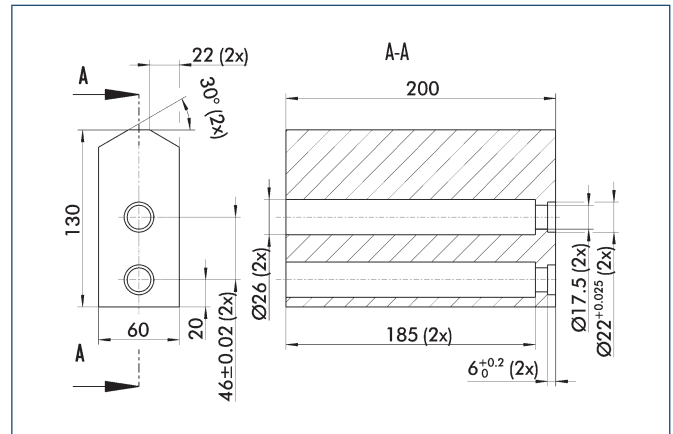

ABR for PGN/PZN

Accessories · Gripper Jaws · For Special Gripper Series



Technical data

Description	ID	Items per ID	Weight [kg]	Material
ABR 50	0300714	1	0.045	Aluminum
SBR 50	0300715	1	0.15	16 MnCr 5
ABR 64	0300725	1	0.093	Aluminum
SBR 64	0300734	1	0.26	16 MnCr 5
ABR 80	0300726	1	0.162	Aluminum
SBR 80	0300735	1	0.455	16 MnCr 5
ABR 100	0300727	1	0.358	Aluminum
SBR 100	0300736	1	1.004	16 MnCr 5
ABR 125	0300728	1	0.638	Aluminum
SBR 125	0300737	1	1.788	16 MnCr 5
ABR 160	0300729	1	1.291	Aluminum
SBR 160	0300738	1	3.45	16 MnCr 5
ABR 200	0300751	1	2.191	Aluminum
SBR 200	0300739	1	6.144	16 MnCr 5
ABR 300	0300752	1	3.236	Aluminum
SBR 300	0300753	1	9.072	16 MnCr 5

ABR 50/SBR 50

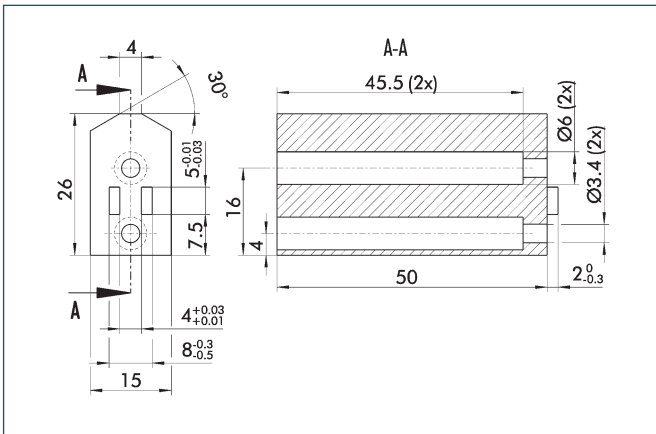

ABR 64/SBR 64

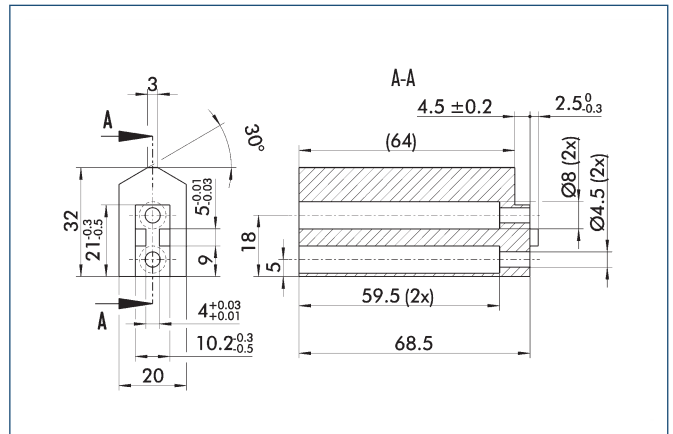

ABR 80/SBR 80

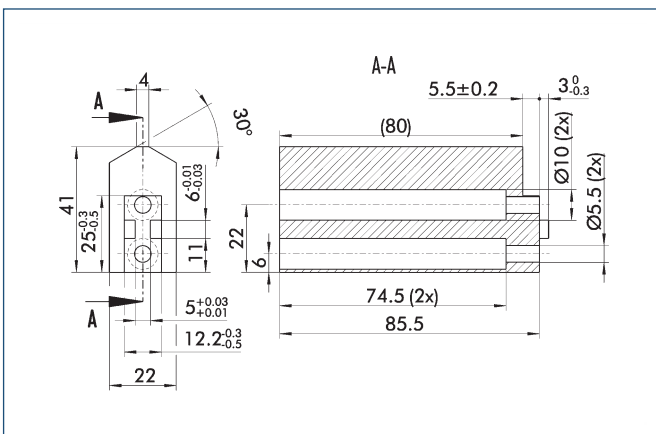

ABR 100/SBR 100

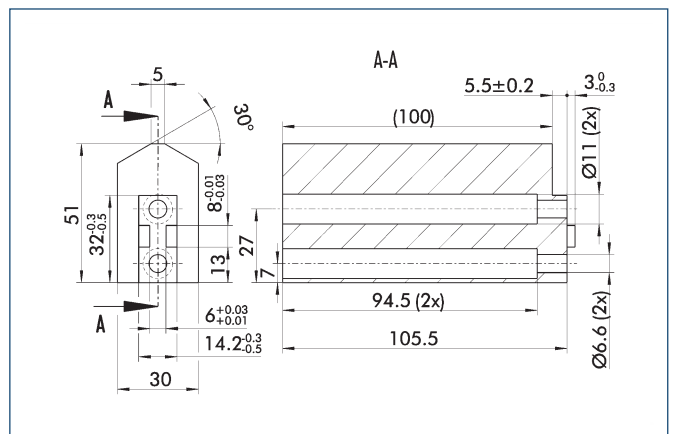

ABR for PGN/PZN

Accessories · Gripper Jaws · For Special Gripper Series

ABR 125/SBR 125

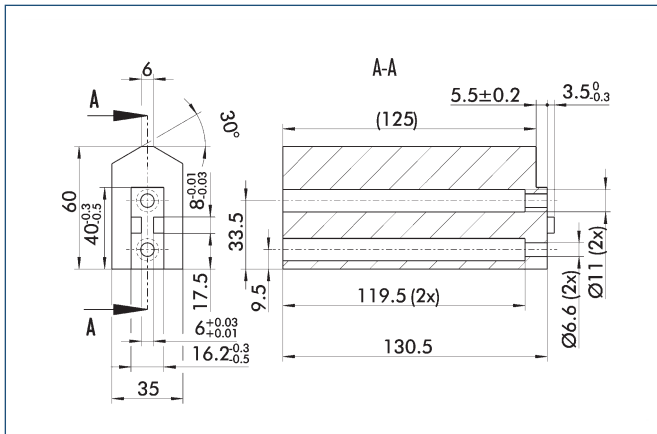

ABR 160/SBR 160

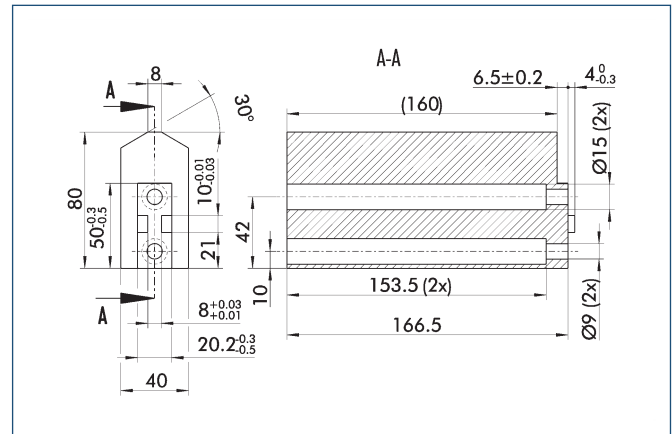

ABR 200/SBR 200

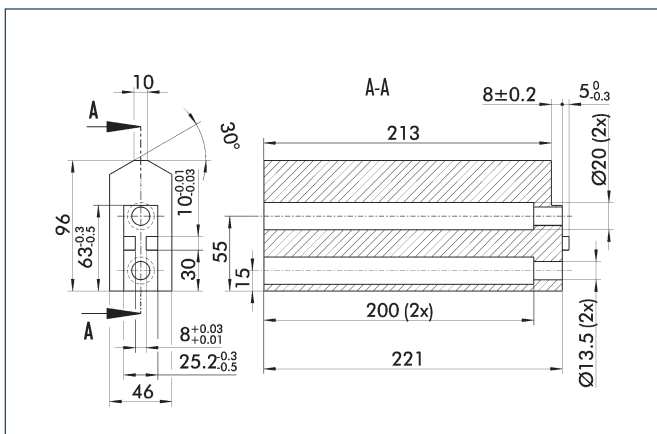

ABR 300/SBR 300

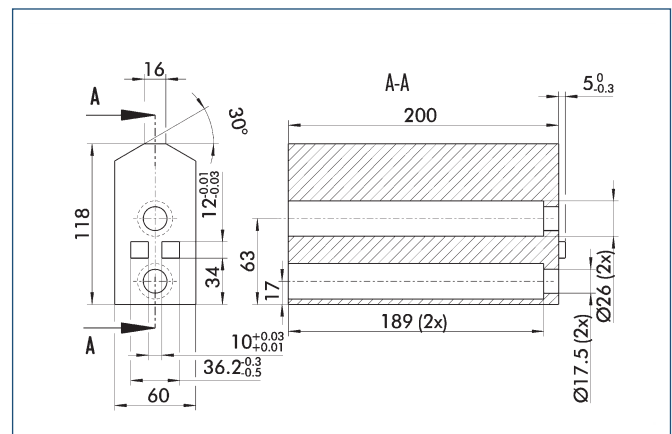

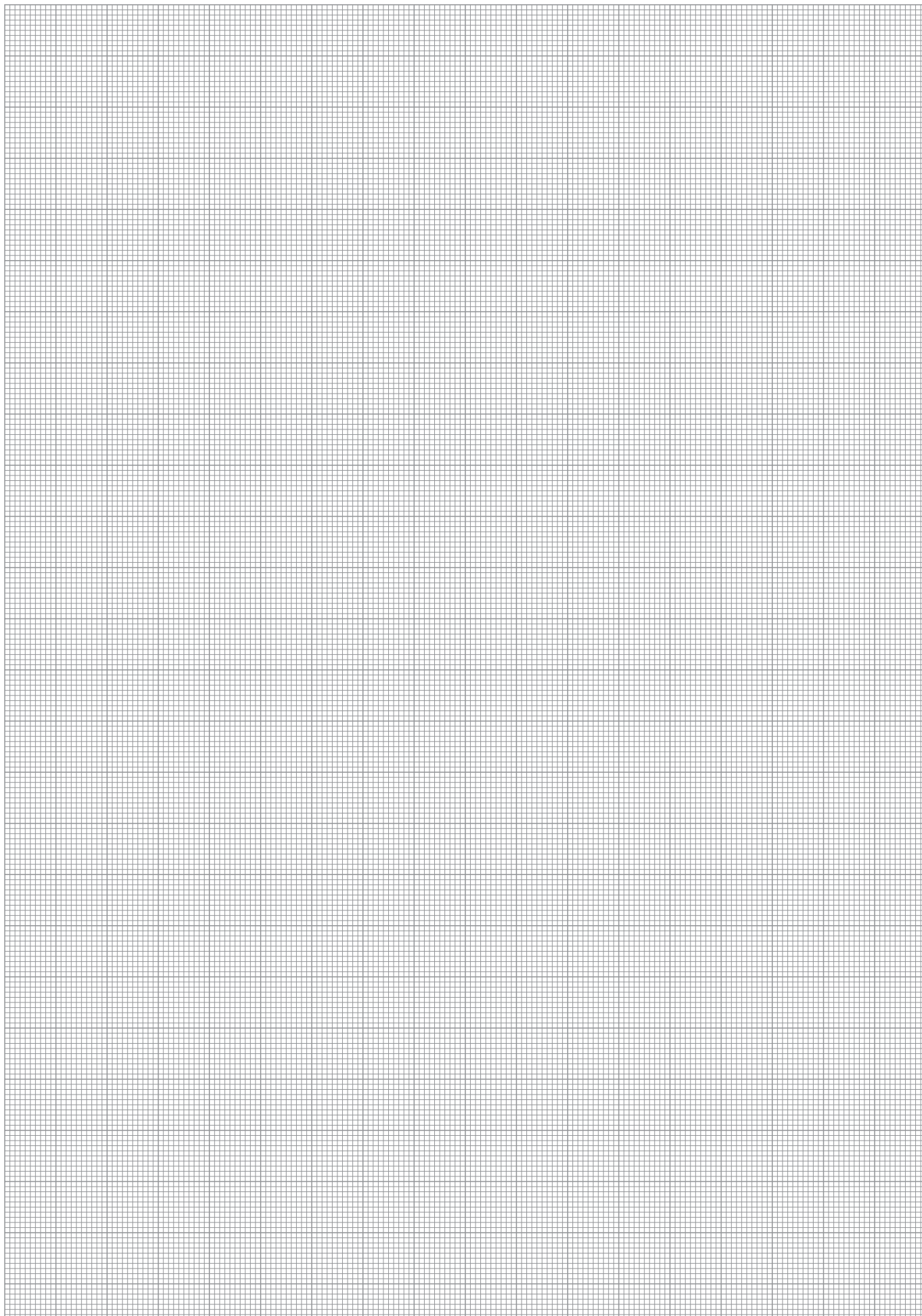

RB for KTG

Accessories · Gripper Jaws · **For Special Gripper Series**



Technical data

Description	ID	Items per ID no.	Weight [kg]	Material
RB 50	0300280	2	0.065	Aluminum

RB 50

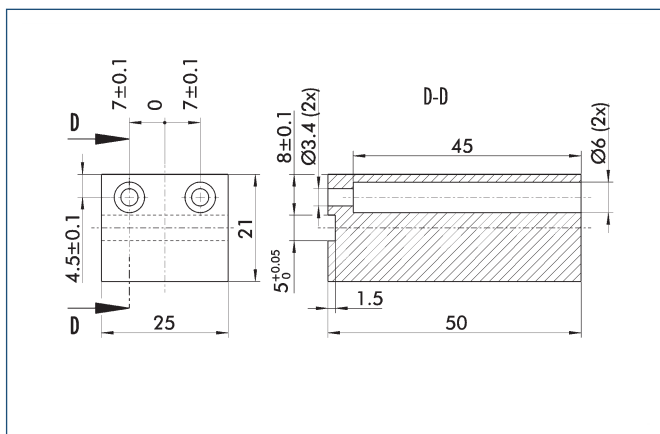

RB for KGG

Accessories · Gripper Jaws · **For Special Gripper Series**



Technical data

Description	ID	Items per ID	Weight [kg]	Material
RB 80	0300284	2	0.141	Aluminum
RB 80	0303089	2	0.141	Aluminum
RB 100	0303090	2	0.32	Aluminum
RB 140	0303091	2	0.467	Aluminum
RB 220	0300286	2	1.354	Aluminum
RB 140	0300285	2	0.467	Aluminum
RB 280	0300287	2	3.102	Aluminum

RB 80

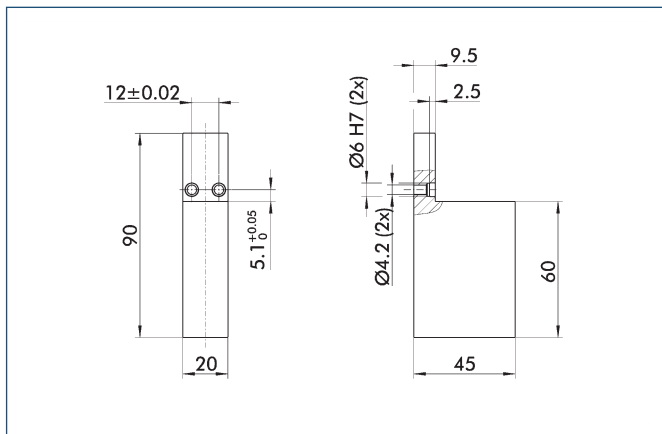

RB 100

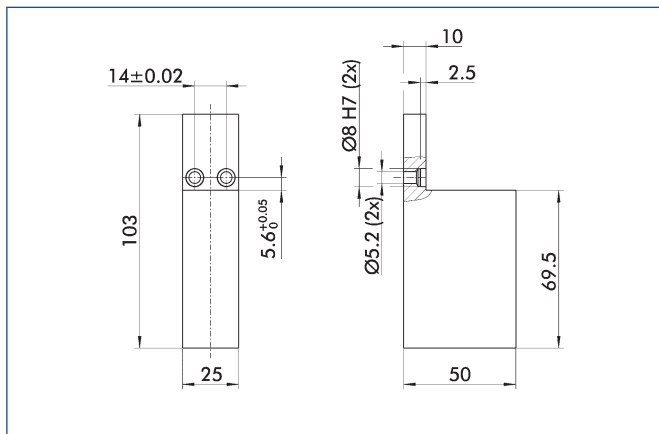

RB 140

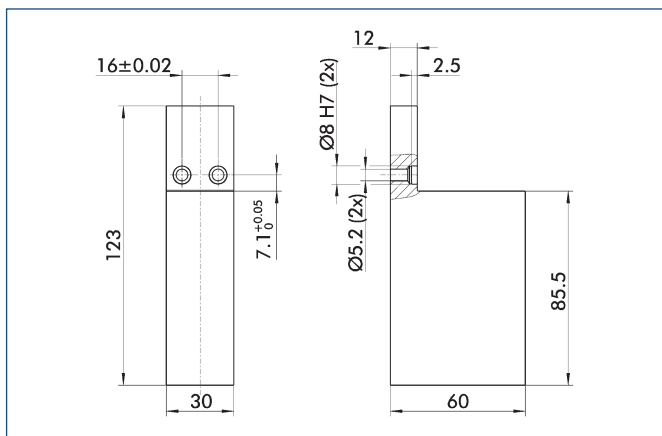

RB 220

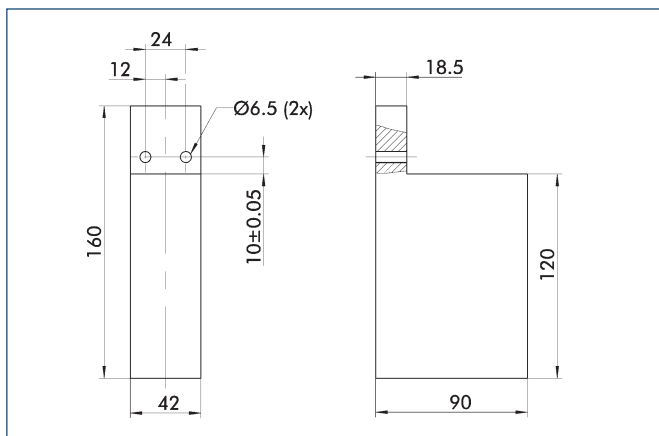

RB for KGG

Accessories · Gripper Jaws · For Special Gripper Series

RB 280

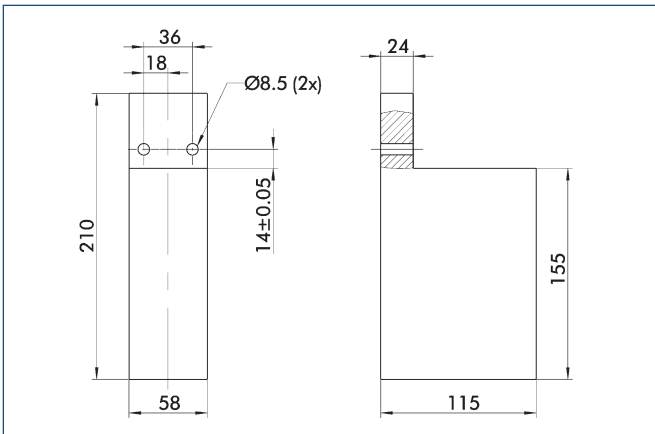

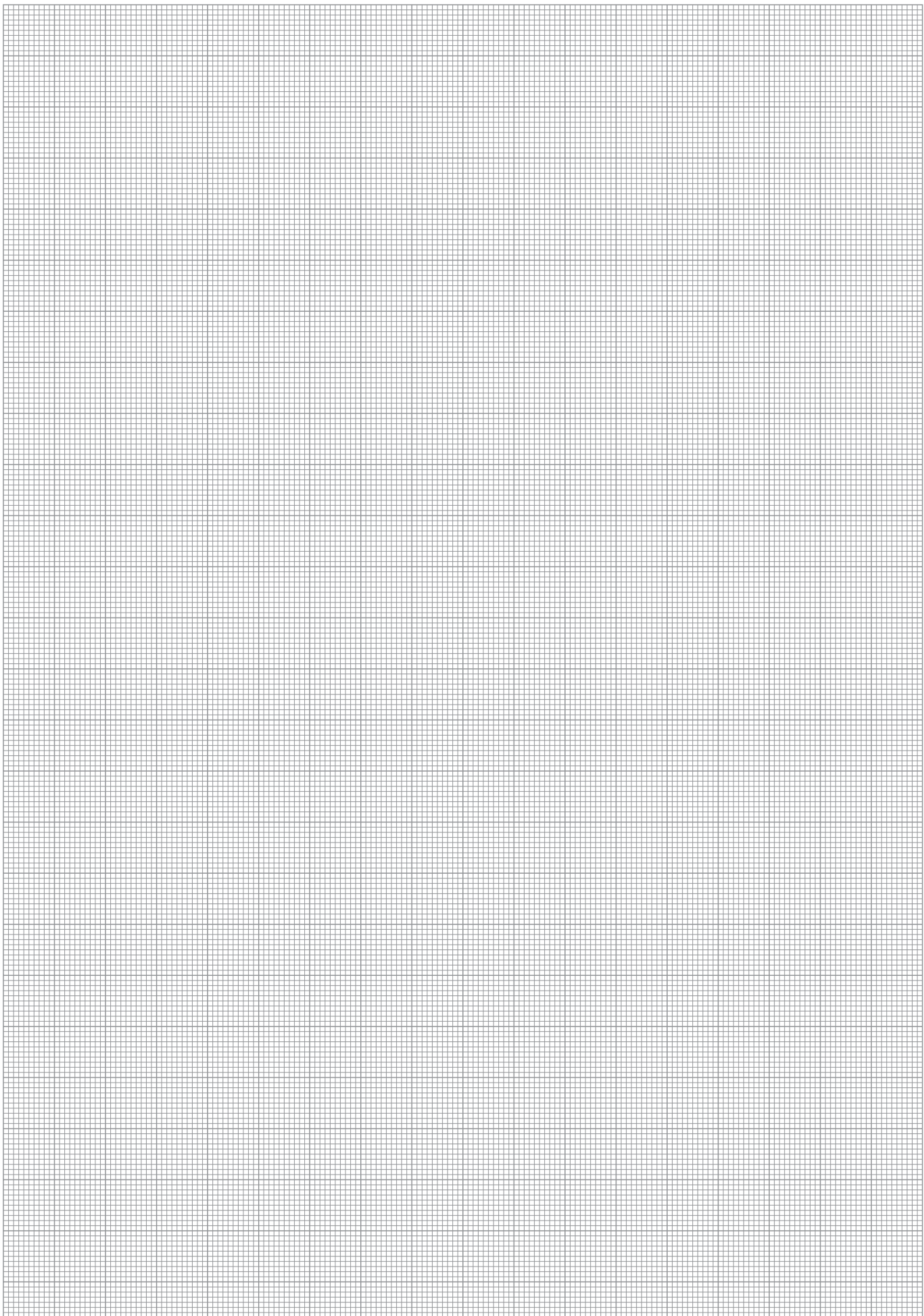

RB for DKG-RR

Accessories · Gripper Jaws · **For Special Gripper Series**



Technical data

Description	ID	Items per ID	Weight [kg]	Material
RB 44	0300281	2	0.038	Aluminum

RB 44

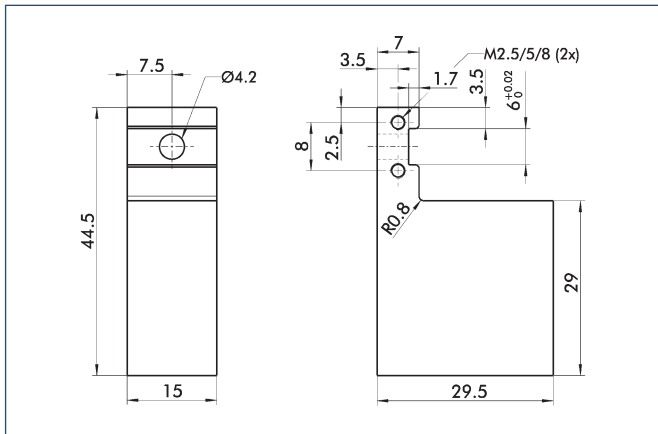

ASB/SBR for UFG

Accessories · Gripper Jaws · **For Special Gripper Series**

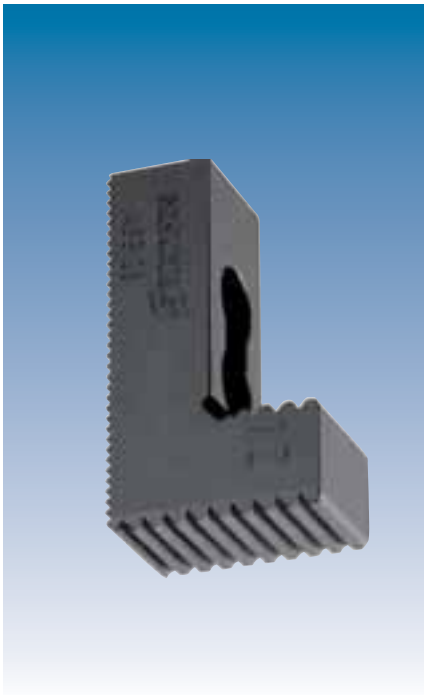

Technical data

Description	ID	Items per ID	Weight [kg]	Material
ASB 26	0302703	3	0.13	16 MnCr 5
ASB 32	0302704	3	0.34	16 MnCr 5
SBR 26	0302707	3	0.29	16 MnCr 5
SBR 32	0302708	3	0.6	16 MnCr 5

ASB 26

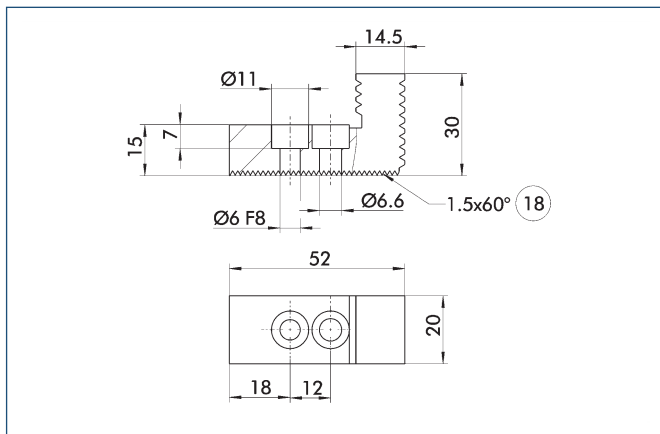

18 Fine serration

ASB 32

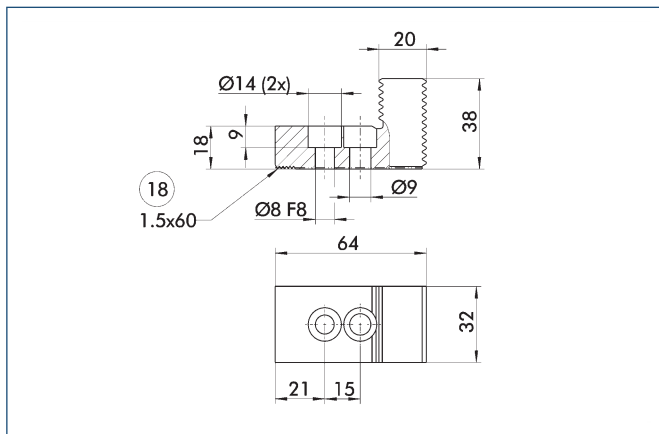

18 Fine serration

SBR 26

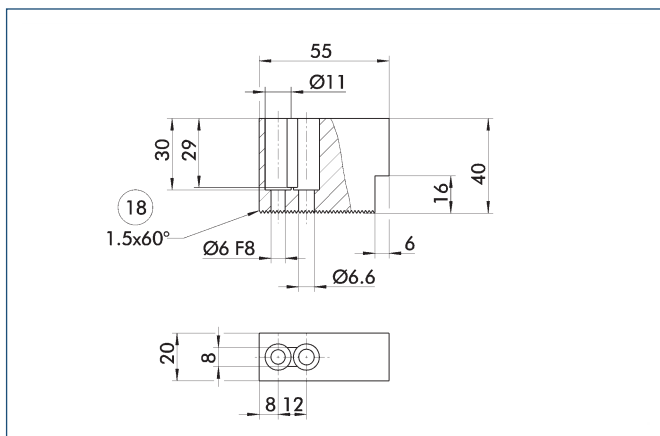

18 Fine serration

SBR 32

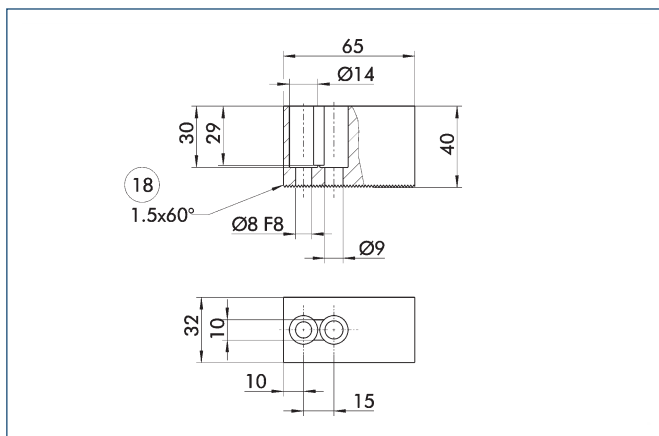

18 Fine serration

ZBH for PFH

Accessories · Gripper Jaws · **Intermediate Jaws**



Technical data

Description	ID	Items per ID	Weight [kg]	Material
ZBH 30	0300220	2	0.66	16 MnCr 5
ZBH 40	0300221	2	0.89	16 MnCr 5
ZBH 50	0300222	2	1.64	16 MnCr 5

ZBH 30 for PFH 30

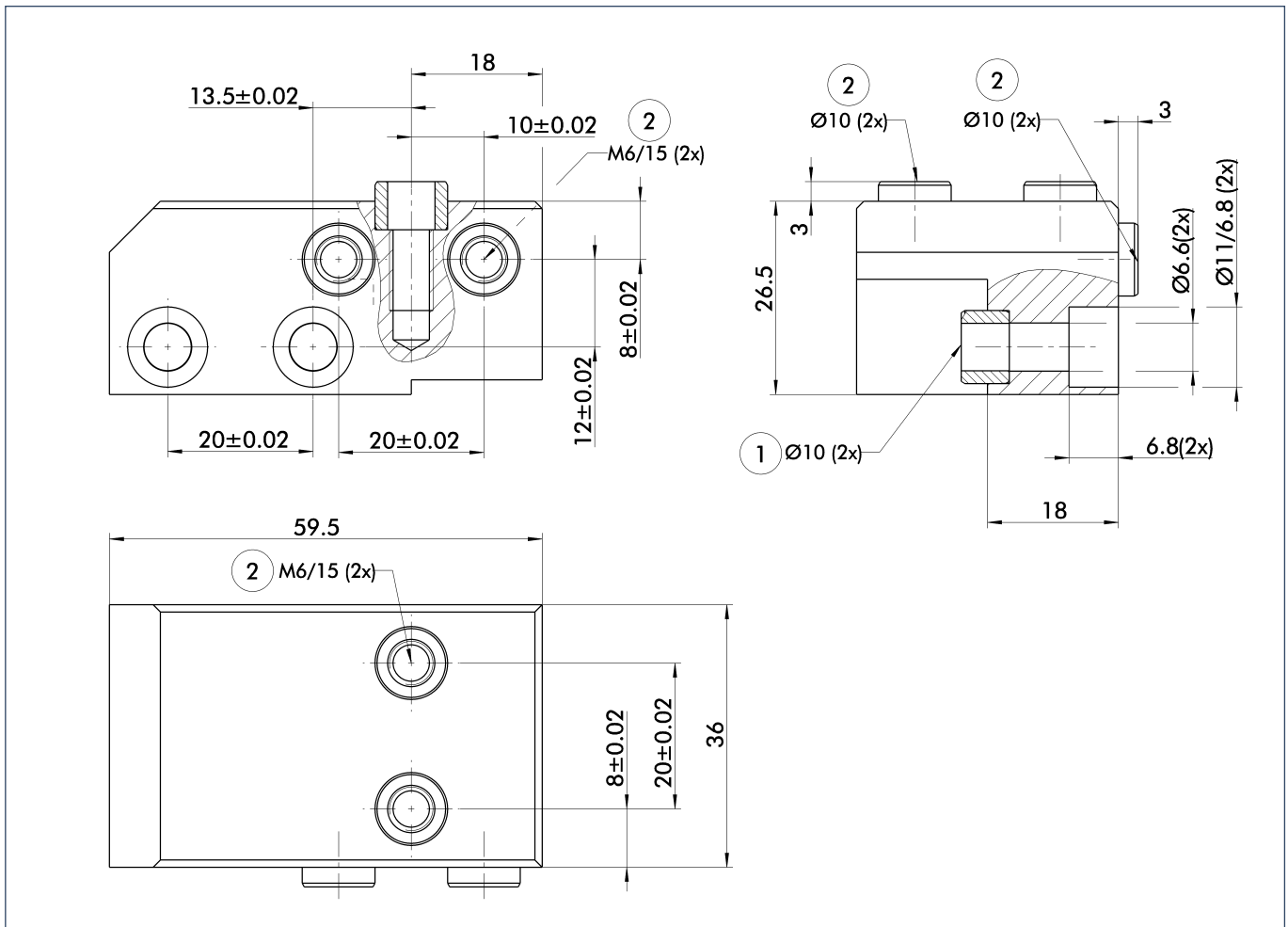

- ① Gripper connection
- ② Finger connection

ZBH for PFH

Accessories · Gripper Jaws · Intermediate Jaws

ZBH 40 for PFH 40

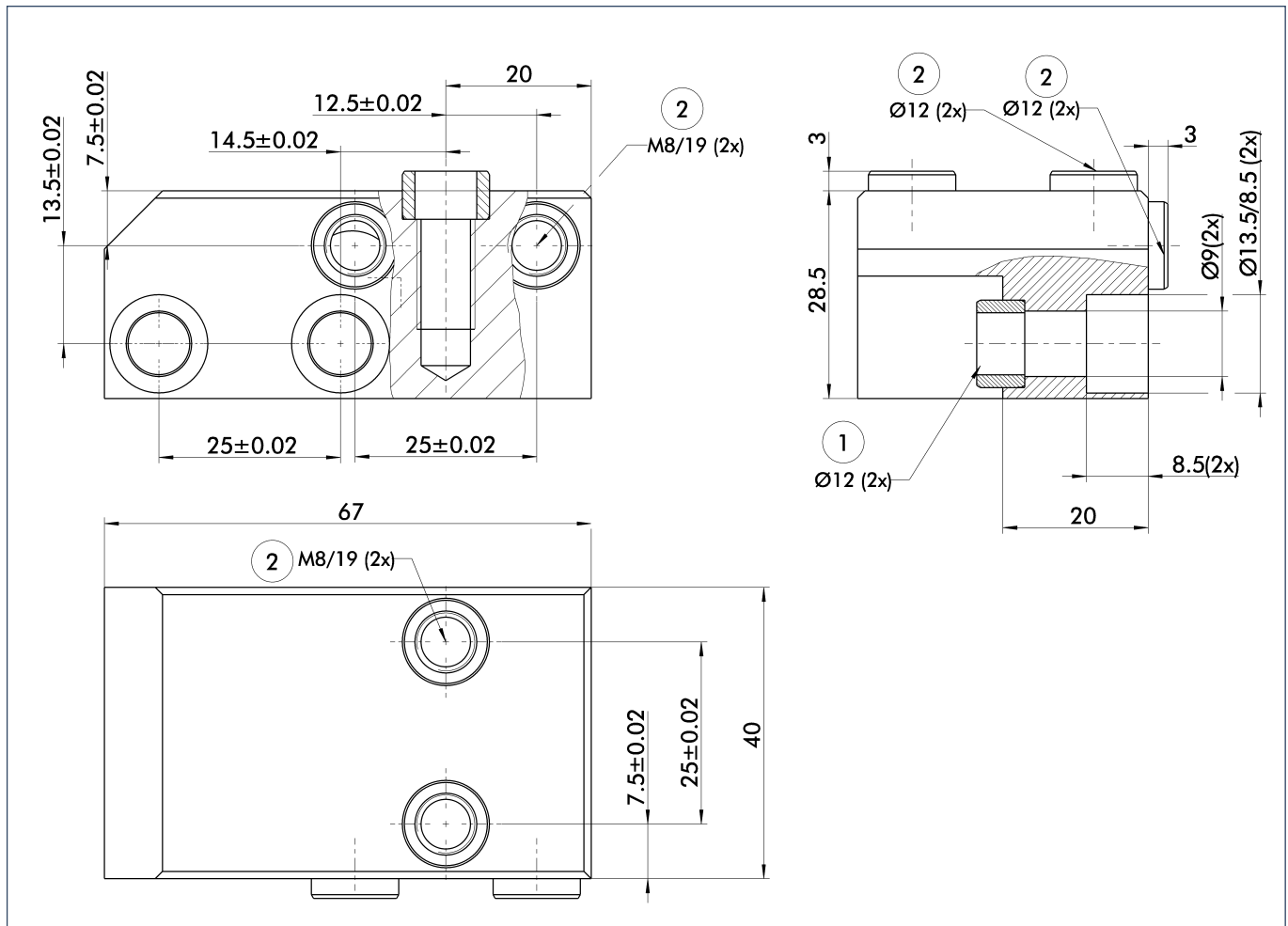

- ① Gripper connection
- ② Finger connection

ZBH 50 for PFH 50

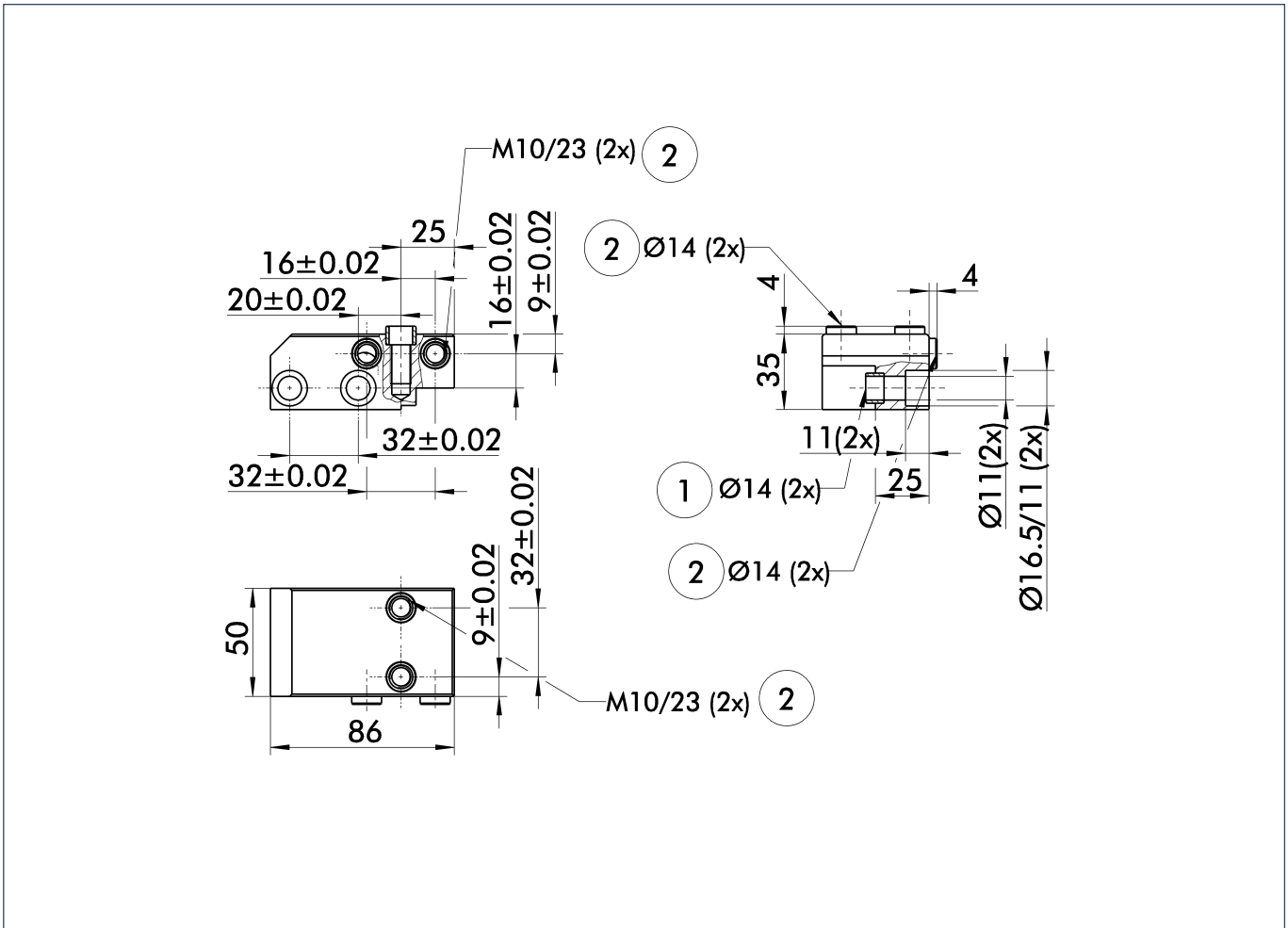

- ① Gripper connection
- ② Finger connection