

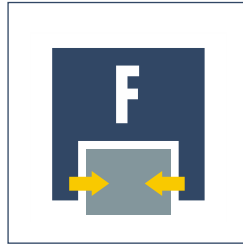

Size
100



Weight
1.35 kg



Gripping force
up to 620 N



Stroke per finger
10 mm



Workpiece weight
3 kg

Application example

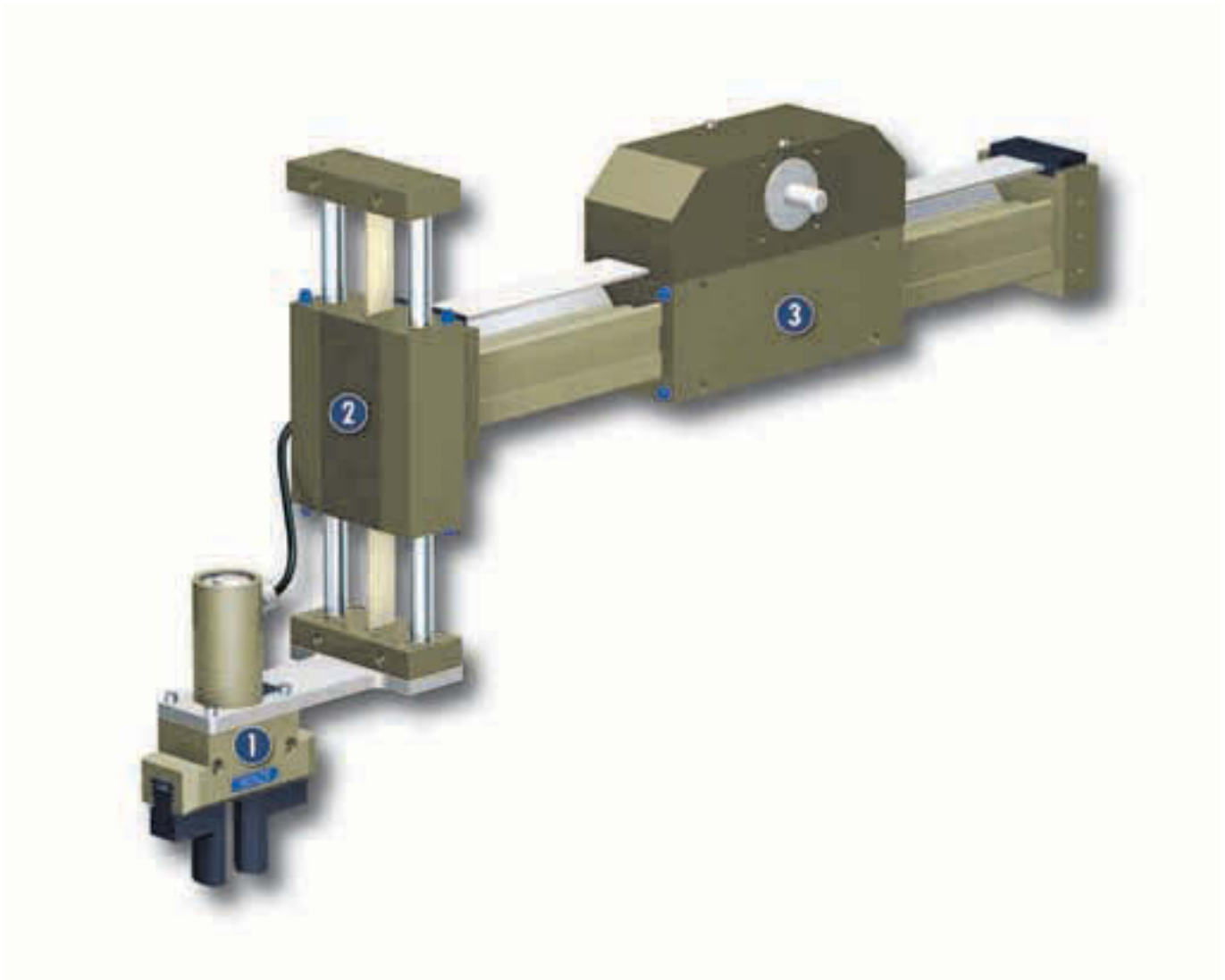

Combined cantilever and short-stroke unit
as rapid pick & place application for
components with a high level of variation

1 EGN 100 Servo-electric
2-Finger Parallel Gripper

2 MLL 25 K Short-stroke Module

3 MLL 40 A Gantry Axis

Universal Gripper

Servo-electric 2-finger parallel gripper with large gripping force and high moment capacities thanks to multiple-tooth guide

Area of application

Ideal standard solution for many areas of application; highly versatile because gripping force, position and speed can be controlled.

Your advantages and benefits

Drive design of servo-motor

for flexibility in use

Control via digital and analog control signals

for simple integration in existing control systems

Pre-positioning capability

to reduce cycle times through a short working stroke

Robust multiple-tooth guidance

for precise handling

High maximum moments possible

suitable for the use of long gripper fingers

Mounting from two sides in three screw directions

for universal and flexible gripper assembly



General information on the series

Working principle

Wedge-hook kinematics

Housing material

Aluminum alloy, hard-anodized

Base jaw material

Steel

Actuation

Servo-electric, by brushless DC servo-motor. A servo-controller is needed to actuate the gripper. We recommend the EGN-C for this purpose.

Warranty

24 months

Scope of delivery

9-pin Sub-D connector, centering sleeves, assembly and operating manual with manufacturer's declaration on CD-ROM

Sectional diagram

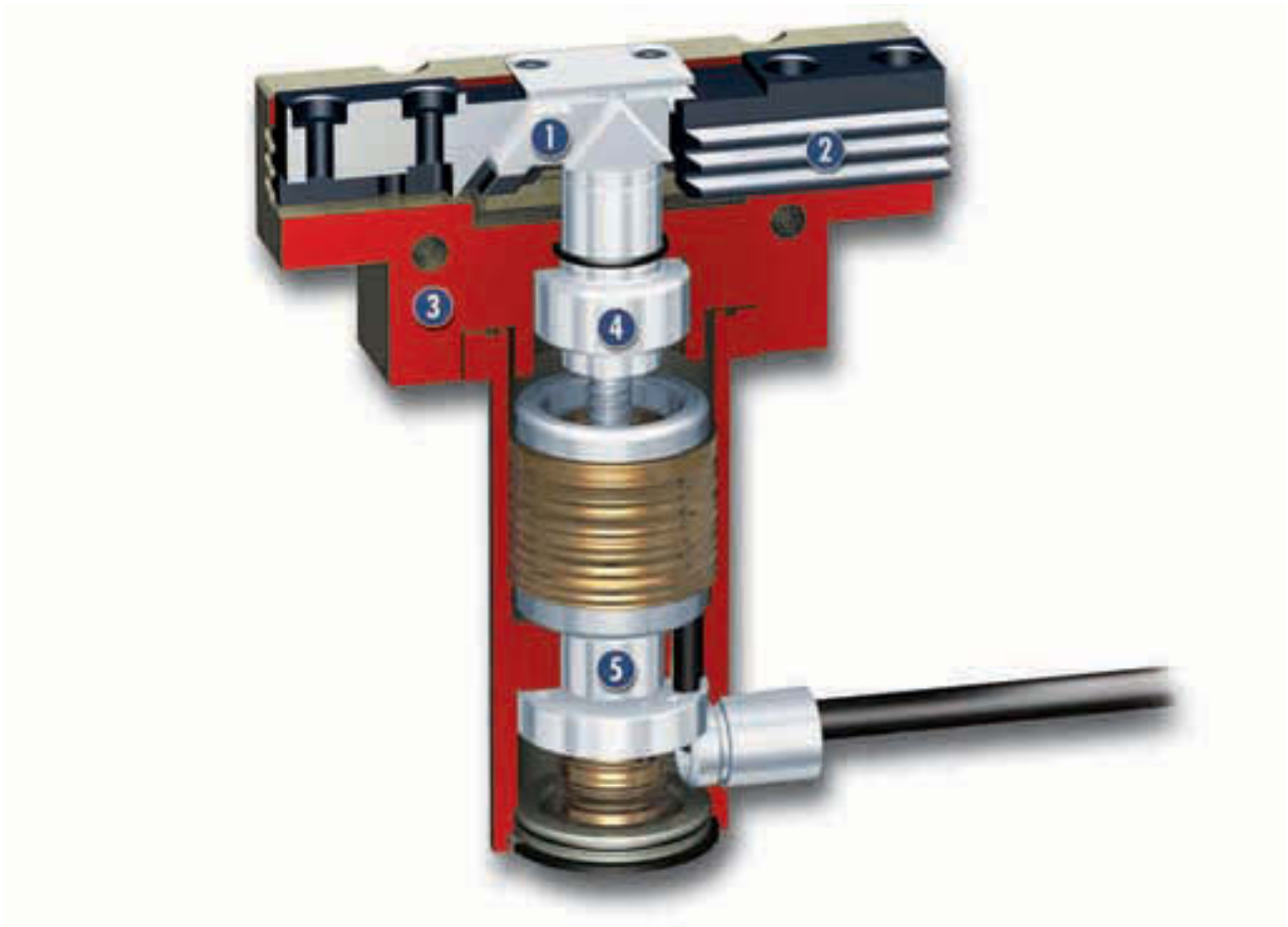

- 1 Kinematics**
wedge-hook system for high power transmission and centric gripping

2 Multiple-tooth guidance
precise gripping even with longer gripper fingers thanks to a high-capacity base jaw guide with minimum play
- 3 Housing**
weight-reduced through the use of a hard-anodized, high-strength aluminum alloy

4 Spindle nut
transforms the rotational movement into the axial movement of the wedge hook
- 5 Drive**
DC servo-motor with resolver

Function description

The roller-bearing mounted spindle nut transforms the rotational movement of the servo-motor into the axial movement of the wedge hook. Through its angled active surfaces, the wedge hook transforms this motion into the lateral, synchronous gripping movement of both base jaws.

Electrical actuation

The electric actuation of the EGN gripper is achieved by the relevant EGN-C control electronics. The control electronics can be integrated in the higher-level servo-controlled concept either via conventional digital and analog inputs/outputs or via the CAN bus (CAN-open protocol) or RS-485 communication interfaces. If integration takes place simply by terminal signals, the gripping force, position, speed and different operating modes are defined by digital and analog inputs. The gripper status can be monitored by means of digital and analog outputs.

Accessories

Accessories from SCHUNK – the suitable complement for the highest level of functionality, reliability and controlled production of all automation components.

Centering sleeves



HUE protective cover



BSWS quick-change jaw system



Controllers



Finger blanks



FMS force measuring system



① For the exact size of the required accessories, availability of this size and the designation and ID, please refer to the additional views at the end of the specific size. You can find more detailed information on our accessory range in the "Accessories" catalog section.

General information on the series

Gripping force

is the arithmetic total of the gripping force applied to each jaw at distance P (see illustration), measured from the upper edge of the gripper.

Finger length

is measured from the upper edge of the gripper housing in the direction of the main axis.

Repeat accuracy

is defined as the spread of the limit position after 100 consecutive strokes.

Workpiece weight

The recommended workpiece weight is calculated for a friction-grip with a coefficient of friction of 0.1 and a safety factor of 2 against slippage of the workpiece on acceleration due to gravity g. Considerably heavier workpiece weights are permitted with form-fit clamping.

Closing and opening times

Closing and opening times are purely the times that the base jaws or fingers are in motion. Valve switching times, hose filling times or PLC reaction times are not included in the above times and must be taken into consideration when determining cycle times.



Gripping force

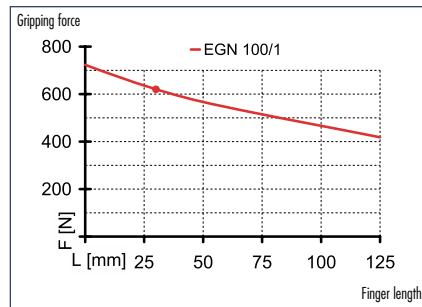

Finger load

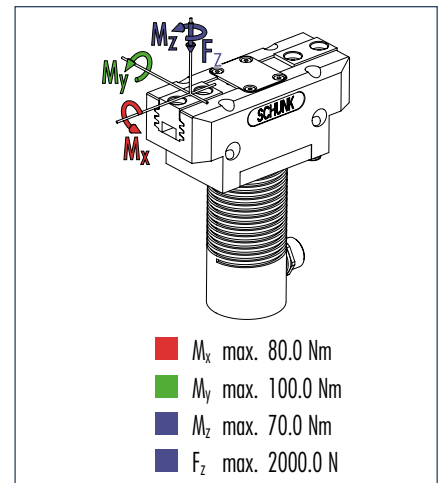

① Moments and forces apply per base jaw and may occur simultaneously. M_y may arise in addition to the moment generated by the gripping force itself. If the max. permitted finger weight is exceeded, it is imperative to reduce the speed so that the jaw movement occurs without any hitting or bouncing. Tool life may be reduced.

Technical data

Designation		EGN 100
Mechanical gripper operating data	ID	0306001
Stroke per finger	[mm]	10.0
Constant gripping force (100 % continuous duty)	[N]	320.0
Max. gripping force	[N]	620.0
Min. gripping force	[N]	140.0
Weight	[kg]	1.35
Recommended workpiece weight	[kg]	3.0
Closing time	[s]	0.35
Opening time	[s]	0.35
Max. permitted finger length	[mm]	125.0
Max. permitted weight per finger	[kg]	1.1
IP rating		40
Min. ambient temperature	[°C]	5.0
Max. ambient temperature	[°C]	55.0
Repeat accuracy	[mm]	0.01
Positioning accuracy	[mm]	on request
Max. speed	[mm/s]	40.0
Max. acceleration	[mm/s ²]	2137.0
Electrical operating data for gripper		
Terminal voltage	[V]	24.0
Nominal current	[A]	2.7
Maximum current	[A]	5.9
Resolution	[mm]	on request
Controller operating data	ID	0307001
Integrated electronics		No
Voltage supply	[VDC]	24.0
Nominal current	[A]	6.0
Maximum current	[A]	12.0
Sensor system		Resolver
Interfaces		I/O; RS-485; CAN-Bus
Weight	[kg]	0.98
IP rating		30

Main views

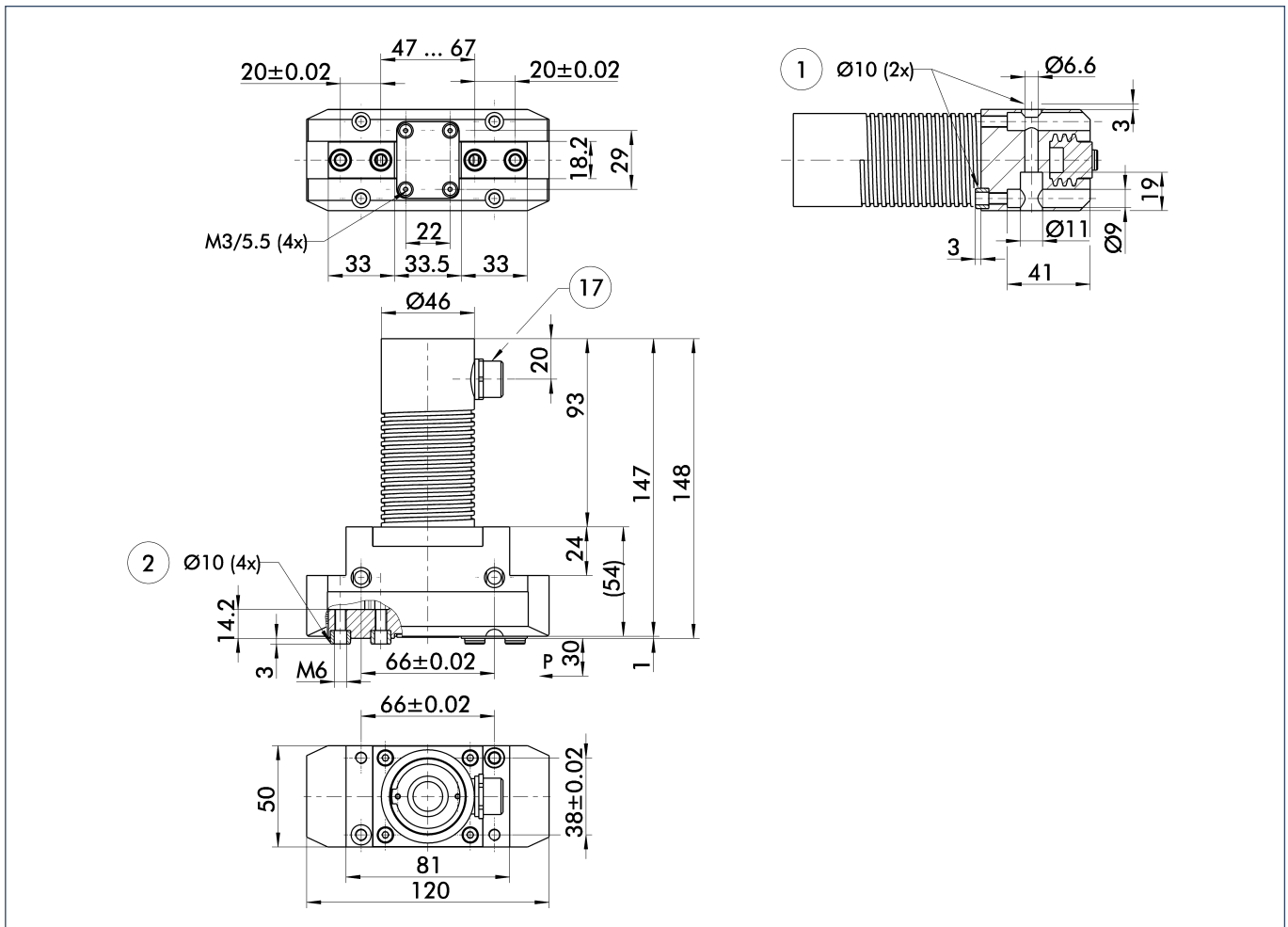

The drawing shows the gripper in the basic version with closed jaws, the dimensions do not include the options described below.

- ① Gripper connection
- ② Finger connection
- ③ Cable outlet

Actuation

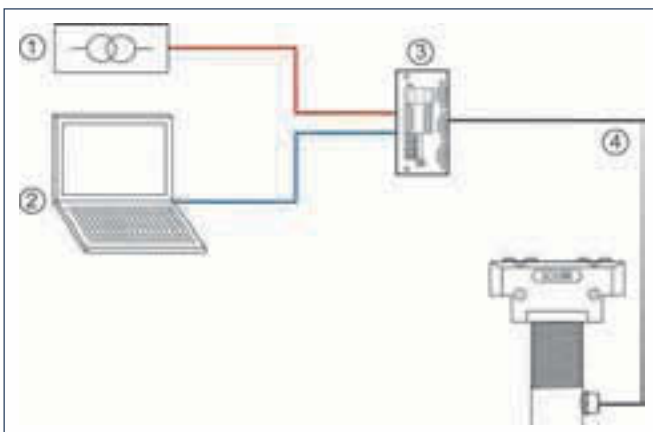

- ① 24 VDC power supply provided by the customer
- ② Control (PLC or similar) provided by the customer
- ③ EGN-C external control electronics (ID No. 0307001)
- ④ Control electronics/gripper connecting cables (5 m cables are included in the scope of delivery, attached to the gripper)

Finger blanks

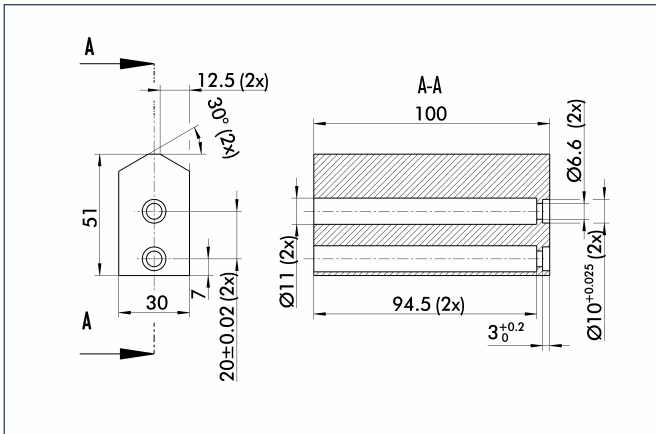

Finger blanks for customized subsequent machining, incl. screw connection diagram.

Designation	Housing material	Scope of delivery	ID
ABR-plus 100	Aluminum	1	0300012
SBR-plus 100	1.6 MnCr 5	1	0300022

FMS force measuring jaws

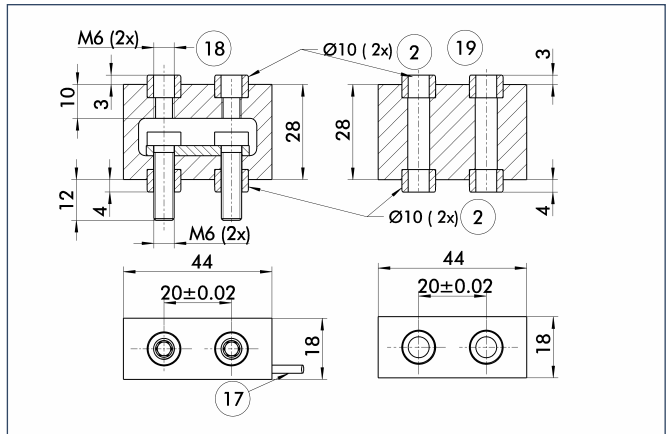

- ② Finger connection
- ①⑦ Cable outlet
- ①⑧ Fine serration
- ①⑨ Air connection

Force measuring jaws measure gripping forces, but can also determine workpiece weights or dimensional deviations. There are active and passive intermediate jaws (FMS-ZBA or FMS-ZBP). At least one active force measuring jaw is required per gripper, the rest can be passive. For each active jaw, an FMS-A1 electronic processor and an FMS-AK connection cable are required.

Designation	ID
FMS-A1	0301810
FMS-AK10	0301822
FMS-AK2	0301820
FMS-AK20	0301823
FMS-AK5	0301821
FMS-ZBA 100	0301836
FMS-ZBP 100	0301837

BSWS quick-change jaw system

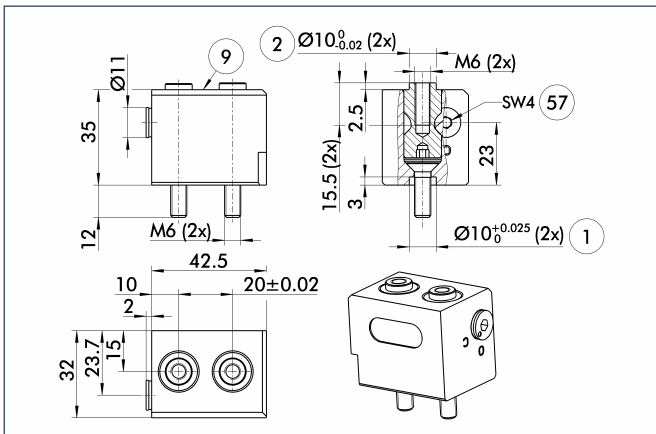

- ① Gripper connection
- ② Finger connection
- ⑨ For screw connection diagram, see basic version
- ⑤⑦ Locking mechanism

The BSWS quick-change jaw system enables top jaws to be changed on the gripper manually and rapidly. An adapter (BSWS-A) and a base (BSWS-B) are required for each gripper jaw.

Designation	ID
BSWS-A 100	0303026
BSWS-B 100	0303027

 You can find more detailed information and individual parts of the above-mentioned accessories in the "Accessories" catalog section.

Maximum permitted overhang

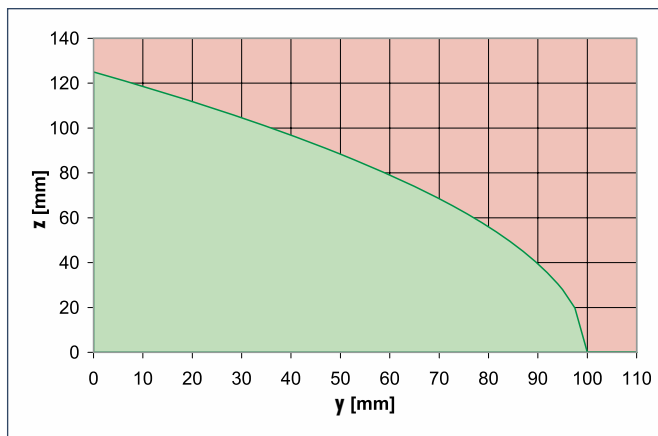
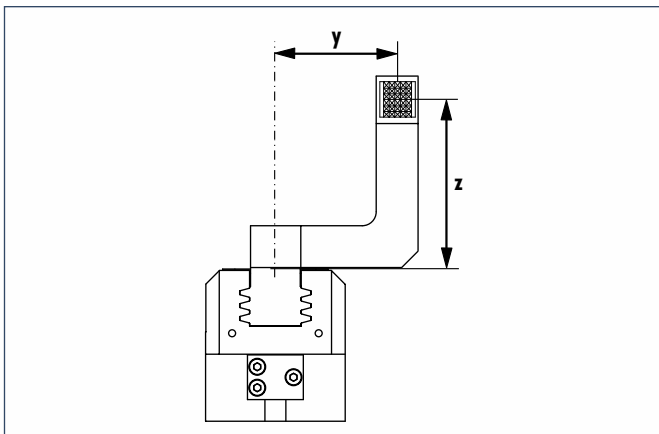

- Permitted range
- Non-permissible range